



MODEL	FE - C660
Standby Power (50Hz)	520KW / 650KVA
Prime Power (50Hz)	600KVA

Standard Features

General Features:

Engine (CCEC Cummins KTA19-G8)
 Radiator 40°C max, fans are driven by belt, with safety guard
 24V charge alternator
 Alternator: single bearing alternator IP23, insulation class H/H
 Absorber
 Dry type air filter, double fuel filter, oil filter, coolant filter
 Main line circuit breaker
 Standard control panel
 Two 12V batteries, rack and cable
 Ripple flex exhaust pipe, exhaust siphon, flange, muffler
 User manual



PHOTO FOR REFERENCE ONLY

Generator Ratings

Voltage	HZ	Phase	P.F (COS ϕ)	Standby Amps	Standby Ratings (KW/KVA)
440/254	50	3	0.8	852	520/650
415/240	50	3	0.8	904	520/650
400/230	50	3	0.8	938	520/650
380/220	50	3	0.8	987	520/650

Prime Power (PRP): Prime power is available for an unlimited number of annual hours in variable load application, in accordance with GB/T2820-97 (eqv ISO8528); A 10% overload capability is available for a period of 1 hour within a 12-hour period of operation.

Standby Power Rating (ESP): The standby power rating is applicable for supplying emergency power for the duration of a utility power interruption. No overload, utility parallel or negotiated outage operation capability is available at this rating.

Sales Promises

FENK provides a full line of brand new and high quality products. Each and every unit is strictly factory tested.

Warranty is according to our standard conditions: a, 15 months, counted on the day sold to the first buyer; b, One year after installation; c, 1000 running hours (accumulated); subject to the earlier one. Service and parts are available from distributors in your location.



ENGINE DATA

Manufacturer / Model:	CCEC Cummins KTA19-G8, 4-cycle
Air Intake System:	Turbo, Water/Air cooling
Fuel System:	PT type fuel pump, EFC
Cylinder Arrangement:	6 in line
Displacement:	18.9L
Bore and Stroke:	159*159 (mm)
Compression Ratio:	13.9:1
Rated RPM:	1500rpm
Max. Standby Power at Rated RPM:	575KW/782HP
Governor Type:	Electronic

Exhaust System

Exhaust Gas Flow:	1773L/s
Exhaust Temperature:	579°C
Max Back Pressure:	10kPa

Air Intake System

Max Intake Restriction:	6.23kPa
Consumption:	635L/s
Air Flow:	10800L/s

Fuel System

100%(Standby Power) Load:	205 g/Kw.h
75%(Standby Power) Load:	205 g/Kw.h
50%(Standby Power) Load::	211 g/Kw.h
100%(Standby Power) Load:	132.2L/h

Oil System

Total Oil Capacity:	50L
Oil Consumption:	≤4g/kwh
Engine Oil Tank Capacity:	38L
Oil Pressure at Rated RPM:	345-483kPa

Cooling System

Total Coolant Capacity:	116.5L
Thermostat:	82-93°C
Max Water Temperature:	104°C



ALTERNATOR SPECIFICATION

GENERAL DATA

Compliance with GB755, BS5000, VDE0530, NEMAMG1-22, IED34-1, CSA22.2 and AS1359 standards.

Alternator Data

Number of Phase:	3
Connecting Type:	3 Phase and 4 Wires, "Y" type connecting
Number of Bearing:	1
Power Factor:	0.8
Protection Grade:	IP23
Altitude:	≤1000m
Exciter Type:	Brushless, self-exciting
Insulation Class, Temperature Rise:	H/H
Telephone Influence Factor (TIF):	<50
THF:	<2%
Voltage Regulation, Steady State:	±1%
Alternator Capacity:	625KVA
Alternator Efficiencies:	95.1%
Air Cooling Flow:	1.035m ³ /s

GENERATING SET DATA

Voltage Regulation:	±5%
Voltage Regulation, Stead State:	±1%
Sudden Voltage Warp (100% Sudden Reduce):	+25%
Sudden Voltage Warp (Sudden Increase):	-20%
Voltage Stable Time (100% Sudden Reduce):	≤6S
Voltage Stable Time (Sudden Increase)	≤6S
Frequency Regulation, Stead State:	≤5%
Frequency Waving:	≤0.5%
Sudden Frequency Warp (100% Sudden Reduce):	+12%
Sudden Frequency Warp (Sudden Increase):	-10%
Frequency Recovery Time (100% Sudden Reduce):	≤5S
Frequency Recovery Time (Sudden Increase):	≤5S

Standard Features

- ◇ Standard Auto Control System
- ◇ Starting batteries(Maintenance-Free & Watering-Free) with connective wires
- ◇ Documents
- ◇ MCCB
- ◇ Oil Drain Valve
- ◇ Special tool for Cummins engine
- ◇ Exhaust System(including until muffler)

Options

- ◇ Base Fuel Tank
- ◇ Daily Fuel Tank
- ◇ Battery Charger
- ◇ Engine Heater
- ◇ Water Separator
- ◇ Permanent Magnet Generator(PMG)
- ◇ Alternator Heater
- ◇ Rainproof Type
- ◇ Soundproof Type
- ◇ Trailer Type
- ◇ Remote Control Panel
- ◇ Automatic Transfer Switch
- ◇ Paralleling System
- ◇ Switch box
- ◇ Spare Parts

Dimension & Weight

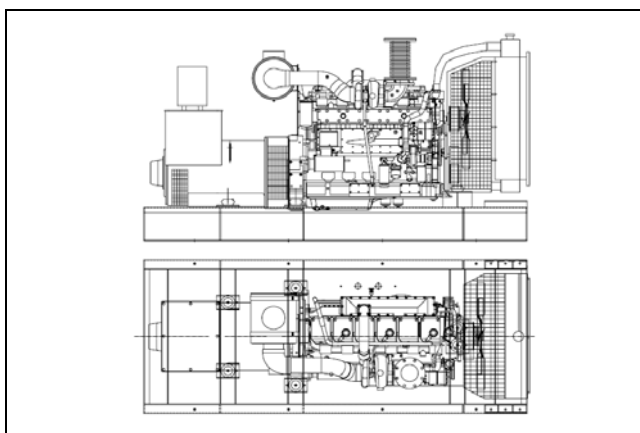

Standard Configuration (Open Type)

Overall Size: 3500 (mm)×1570 (mm)×2050 (mm)
Weight: 4500kg

With Base Fuel Tank

Overall Size: 3500 (mm)×1570 (mm)×2050 (mm)
Weight: 4600kg

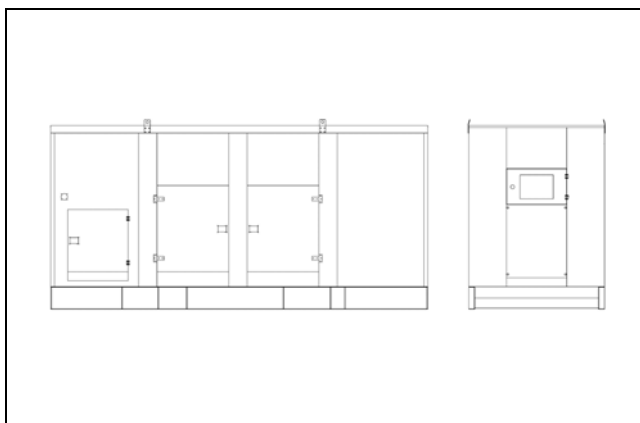

Soundproof Type

Overall Size: 4630 (mm)×1660 (mm)×2250 (mm)
Weight: 5945kg

Standard Control Panel



Standard Control Panel uses micro processing technique integrating digital, intelligent and network techniques which can carry out functions including auto start/stop, data measure, alarming. The controller uses LCD, English display interface with operation easy and reliable. It can be widely used in all types of generator automatic control system for compact structure, advanced circuits, simple connections and high reliability

Auto Module Control Panel



Auto Module Control Panel is the configuration for nobody on duty controlling generators. This kind of panel adopts auto module control system, with large LCD display to show the menu.

Features: MRS10-can receive remote output signal from ATS and realize auto start and stop of generators.

MRS16-can realize all functions of MRS10, add RS232 interface which can communicate with PC to realize remote operation.

AMF25-Auto Mains Failure controller, can realize all functions of MRS16, furthermore can detect ATS and control directly.

Auto Parallel Control Panel



Automatic Parallel Control Panel This new automatic parallel system adopts intelligent modules, inserted and folded installed, no need the peripheral relay and logic circuit. The main switch adopts electronic breaker or frame breaker, combined together with the generator, which is very reliable. One generator, one panel. The panel can be used both for singly and parallel. It is only need to parallel generator with such panel when the capability needs to be enlarged in the future.